

PRODUCT SHEET · FICHE PRODUIT



**ATELIER
ALAIN
ELLOUZ**



CELINE

.édition



ATELIER ALAIN ELLOUZ
PARIS

CELINE

.édition

PENDANT LIGHT SUSPENSION

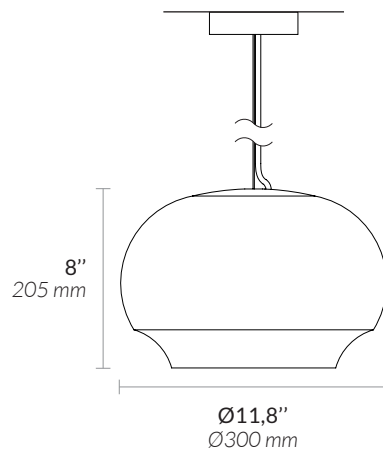

CELINE®
DESIGN BY ATELIER ALAIN ELLOUZ
MADE IN FRANCE

MATERIALS MATÉRIAUX

Alabaster
Albâtre

SUSPENSION SYSTEM SYSTÈME DE SUSPENSION

Mat white canopy Ø100mm, stainless steel wire rope with transparent electric cable (max. 2000 mm)
Pavillon blanc mat Ø100mm, Filin avec câble transparent Longueur ajustable sur place (max. 2000 mm)

LIGHTING SYSTEM SYSTÈME D'ÉCLAIRAGE

E27
Recommended bulb / Ampoule recommandée :
LED bulb E27 9W 2700K 800 lm - Dimmable
Ampoule LED E27 9W 2700K 800 lm - Variable

The alabaster diffuses between 40 and 60% of the light source lumens

L'albâtre diffuse entre 40 et 60% des lumens de la source lumineuse

WEIGHT POIDS

Approx. 15,9 lb
Env. 7,2 kg

REFERENCE RÉFÉRENCE

ED-0025

WARRANTY GARANTIE

2 years warranty
Garantie 2 ans

EDITION.ATELIERALAINELLOUZ.COM

On request : list of specific accessories available to create compositions of multiple pendants.
Sur demande : liste d'accessoires spécifiques dédiés à la création de compositions.

